

Scale 1:1

Interface according IEC 60169-8

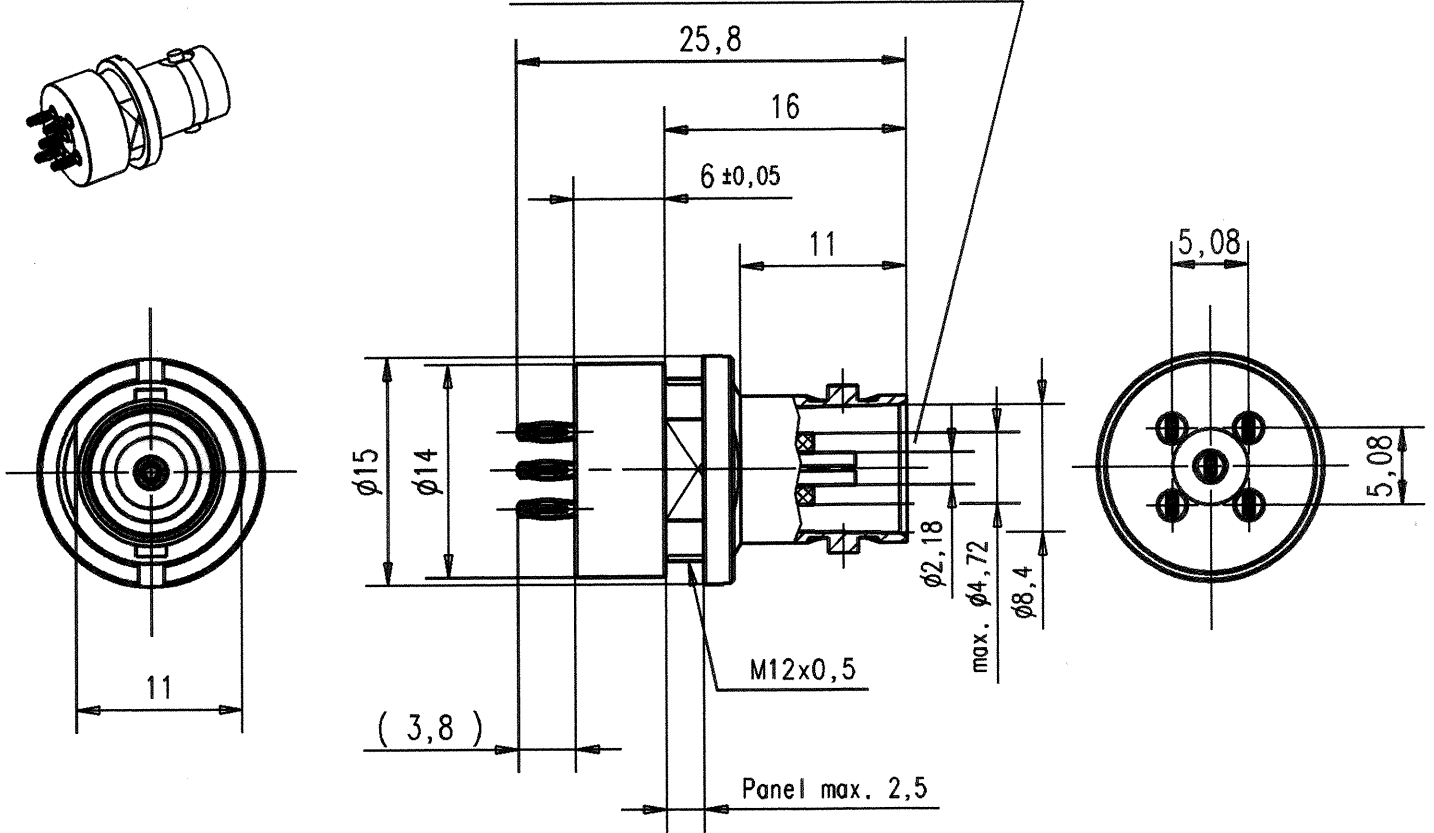

PCB-thickness: 2,1-3,2mm
 Insertion force per contact: 200N
 Retention force per contact: 20N
 according: IEC 352-5

Montagedurchbruch /
 Panel cut out

Montagebohrungen /
 Mounting detail

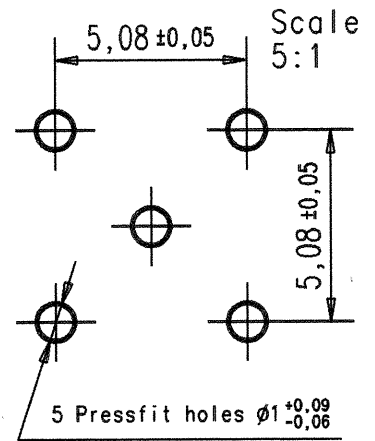
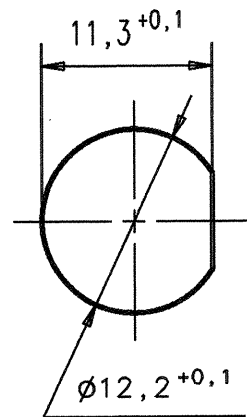

Part	Material	Finish
Body	CuZn39 Pb3	Optalloy
Centre contact (Interface)	CuBe	1,3µm Au
Insulator	PTFE	

Gestellware	Ja	X	Nein	Werkstueckkanten:	-0.1	+0.1	Grossserienteil gefertigt nach Anlage	Ja
Verpackung	NR. : 1010051			DIN-6784	AGK 2677, AGK 2678, AGK 2679			
	Anzahl: 50			() Konstruktions-	Masse werden bei Abnahme			Werkstueckvolumen
QP	TM	PA	LV	SP	masse	gesondert geprueft: DIN-406	V = mm³	Werkstueckoberflaeche
								A = mm²

IME CONNECTOR SYSTEMS GMBH

ALLGEMEINTOL.
 ISO 2768
 mH

Masstab: 2:1

(75 Ω)

	Datum	Name
Bearb.	09.12.98	Schwaer
Gepr.		
Norm		

Anbaubuchse
 p.c.p. mount jack

ENTWURF	d	Panel 1,5-->2,5	19.01.00	RSc
ENTWURF	c	New design	25.02.99	RSc
ENTWURF	b	New design	28.01.99	RSc
ENTWURF	a	Shorten	25.01.99	RSc
Nr.	Zust.	Aenderung	Datum	Name

2669.05.2012.205

Rev.
 d