

Empfehlung / Recommended
PCB-Lötfläche / PCB-Footprint

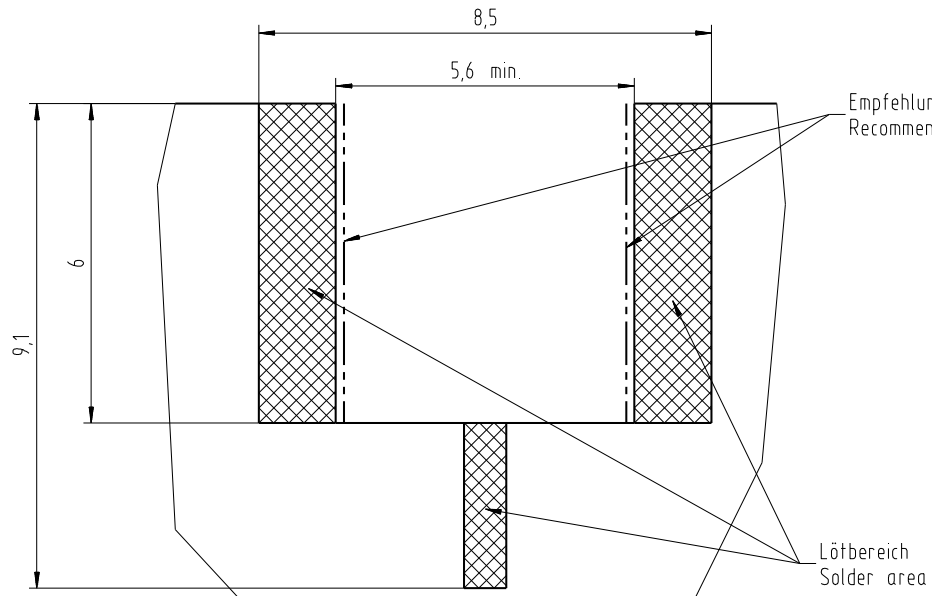

SCALE 10:1

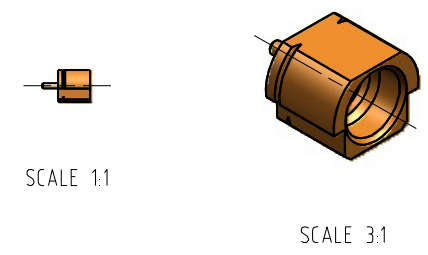

				general tolerance ISO 2768 mH		scale: 10:1		
				date 19.07.12 name Schwaer		Limited detent		
generate checked Norm 057746				date 26.10.12 name RSch		PSMP(m)-Anbaustecker PSMP(m)-p.c.b. mount plug		
design nr. a rev. Change acc. alteration sim. date 26.10.12 name RSch						5025.PSMP.1010.09'		Rev. a