

Kabelzuschnitt / Stripping dimension:
Kabel / Cable: IPEX MHF4 / Murata MXTK 88 / 92

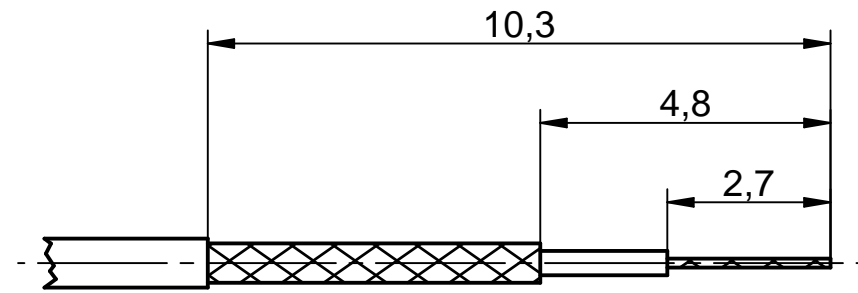

Aussen crimpen / out crimp: SW 2,67
Innen / in : löten / solder

(Nicht IEC-Standard!!)
(No IEC-Standard!!)

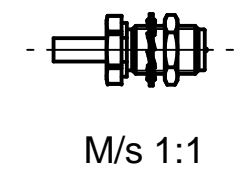
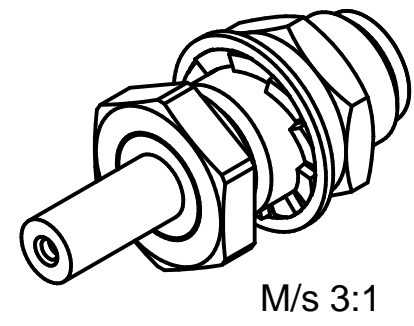

		general tolerance	scale: 8:1		
		ISO 2768 mH angle: ±5°	Assembly instruction: M-130 Stripping dimension: K-1		
	date	name	SMA-Kabelstecker rev. pol.		
generate	29.01.18	kpolgar			
checked	29.01.18	Pölz			
	Norm		SMA-Cable mount plug rev. pol.		
				5474.42.1412.21	
				Rev.	
nr.	rev.	alteration	date	name	surface code