

Revision history				
Change ID	Rev.	Alteration	Date	Name
PEC_11952_01	A02	add alternative pcb layout	24/11/22	dni

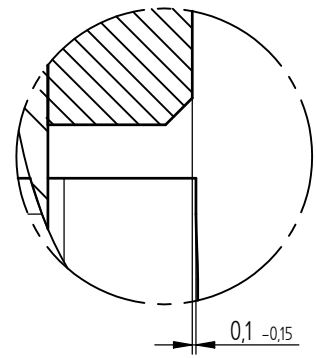
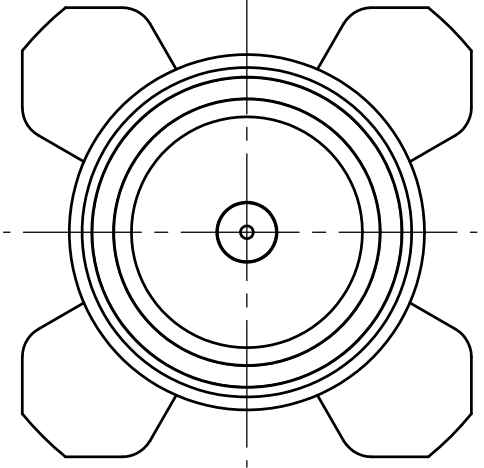
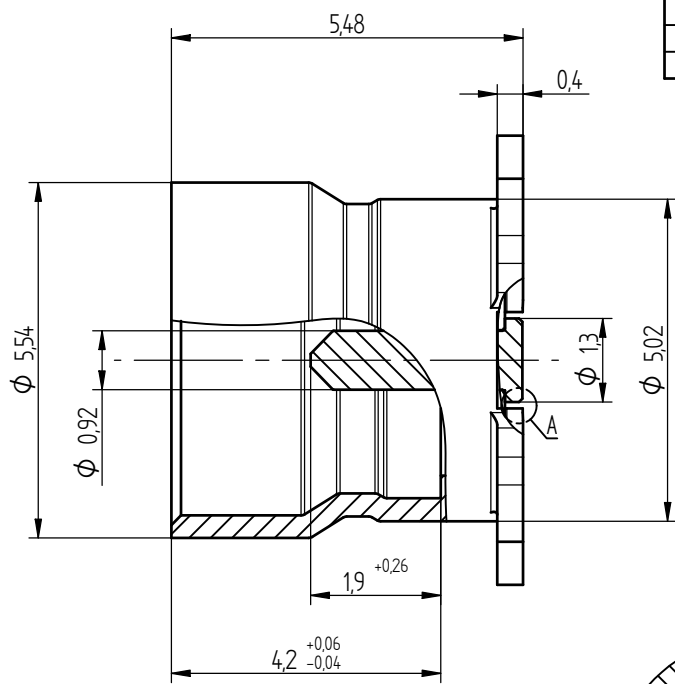
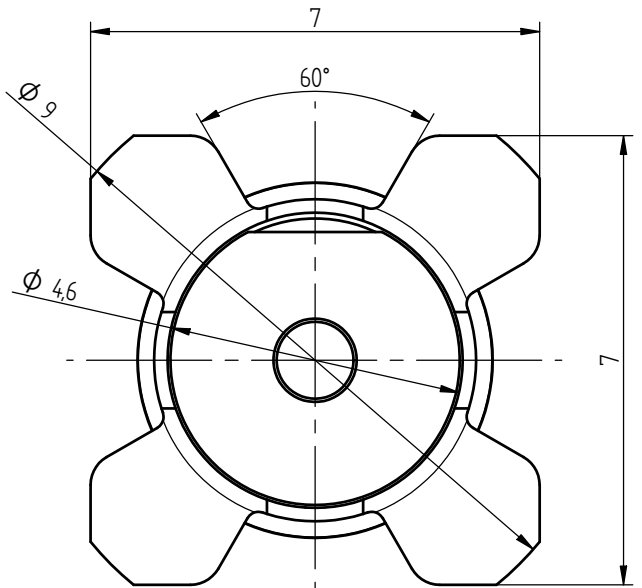

Tape and reel	AGK-6079
Parts/reel	700pcs
Parts/m	83,3
Forward run	0,3m
After run	0,4m
Reel length	9,4m
Reel diameter	330mm

recommended PCB layout

alternative PCB layout

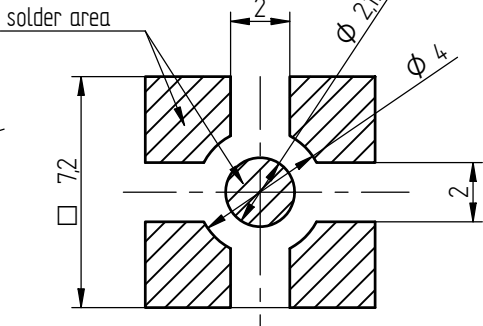
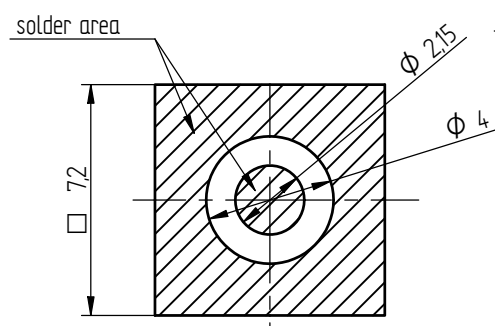

Interface: Limited detent

Detail A
Scale 100:1

Projection - ISO 5456 	Unit system - Metric All dim. in [mm]	General tolerance ISO 2768 mH	Assembly instruction	Document type Acceptance drawing
Created by carlos.sheng	Approved by Dony Ni	Title PSMP pcb mount plug	Drawing number 7819.PSMP.1010.00Z	Surface code
Supplementary title PSMP pcb mount plug			Rev. A 02	Date of issue 01/07/2022
			Lang. EN	Sheet 1/2

