

Pos.	Stk./ pcs	Bezeichnung/ Description	Typ-Nr./ Type-No.	Bemerkung/ Remark
①				
②	1	Kabelstecker Cable mount plug	4291.72.1310.119 (1078055)	
③	0,5	Kabel Cable	Hirose U.FL-2LP-066-A300 (1135808)	
④				
⑤				
⑥				
⑦				

Anzahl der Kabel / No. of cable	Stueck / Pcs
---------------------------------	--------------

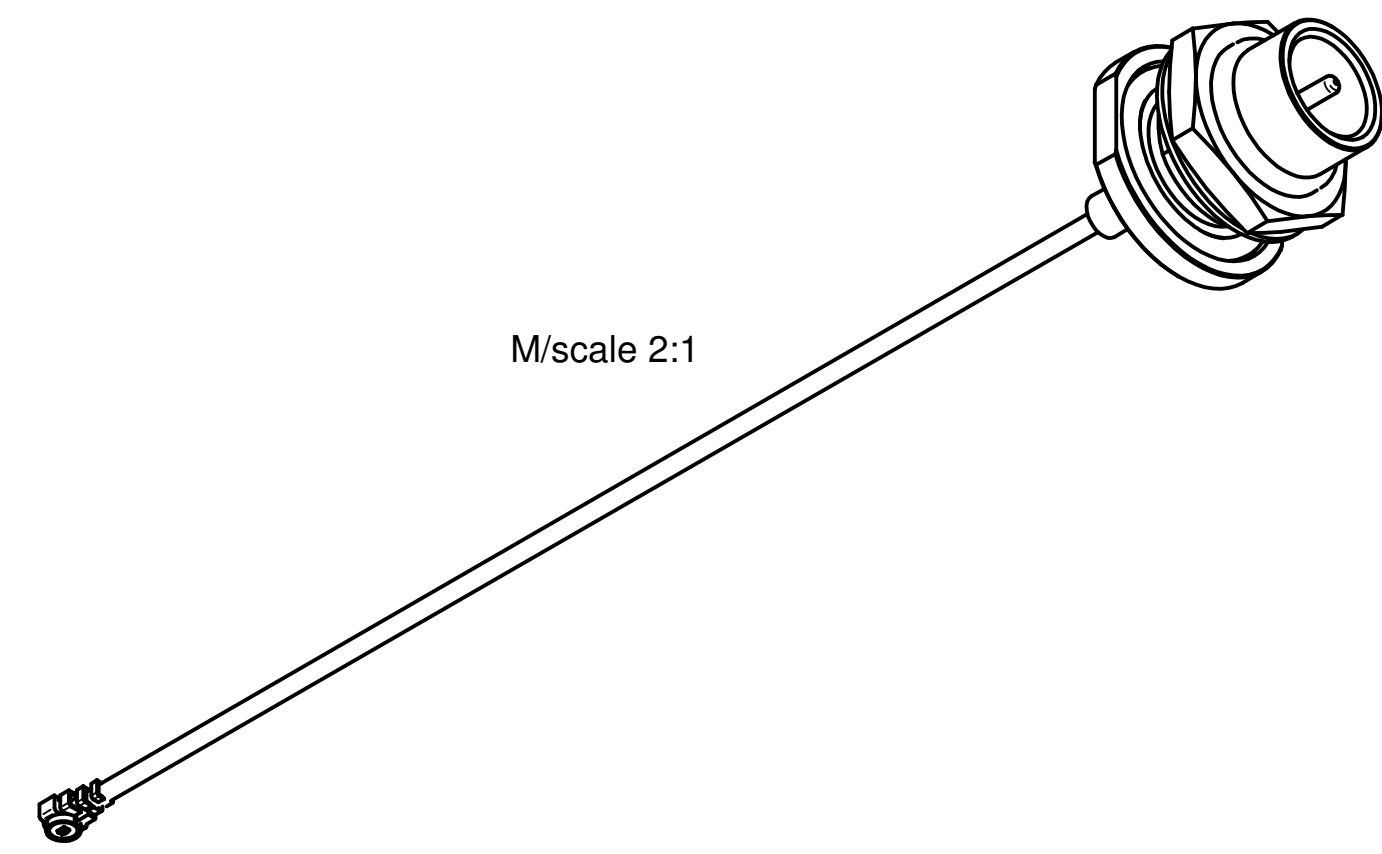
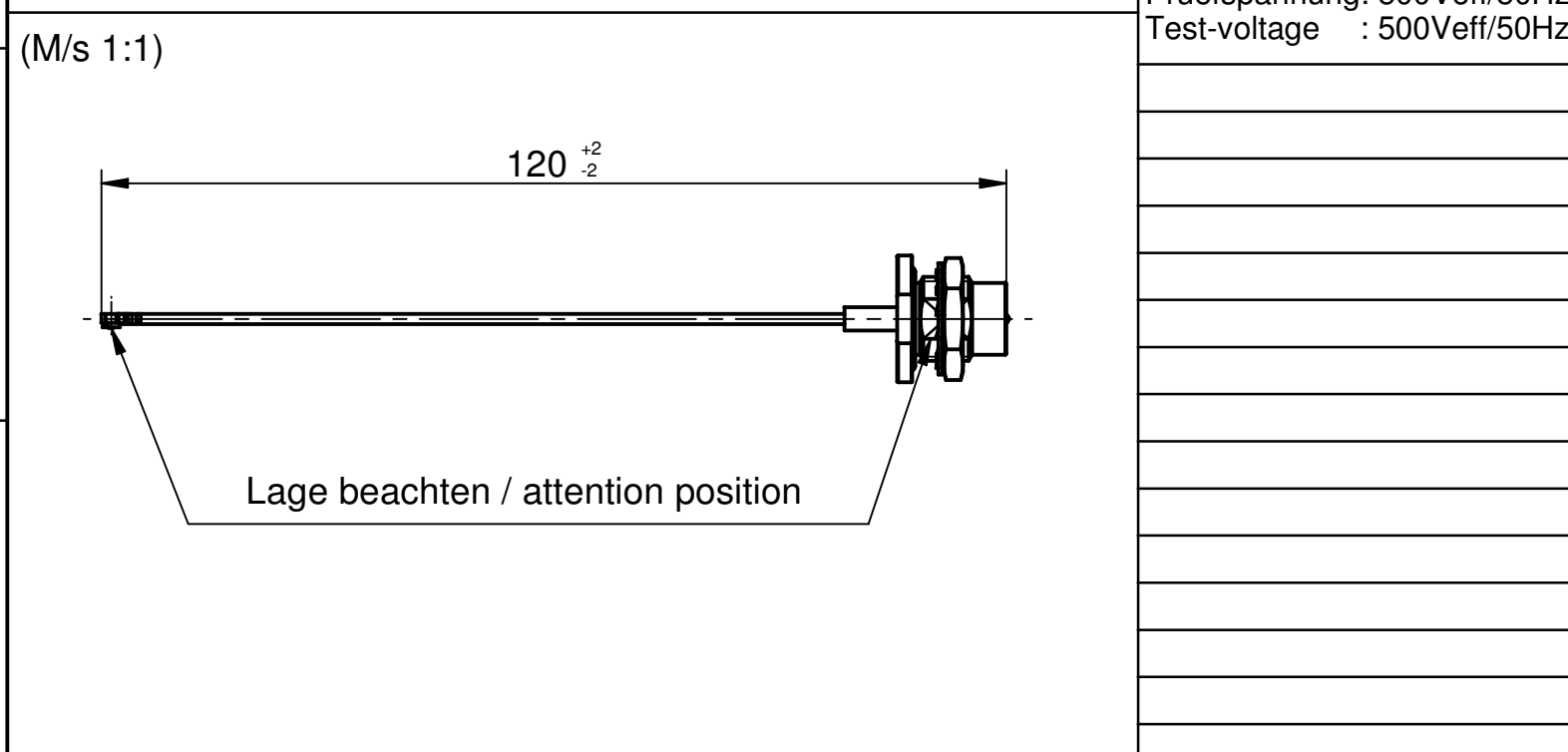
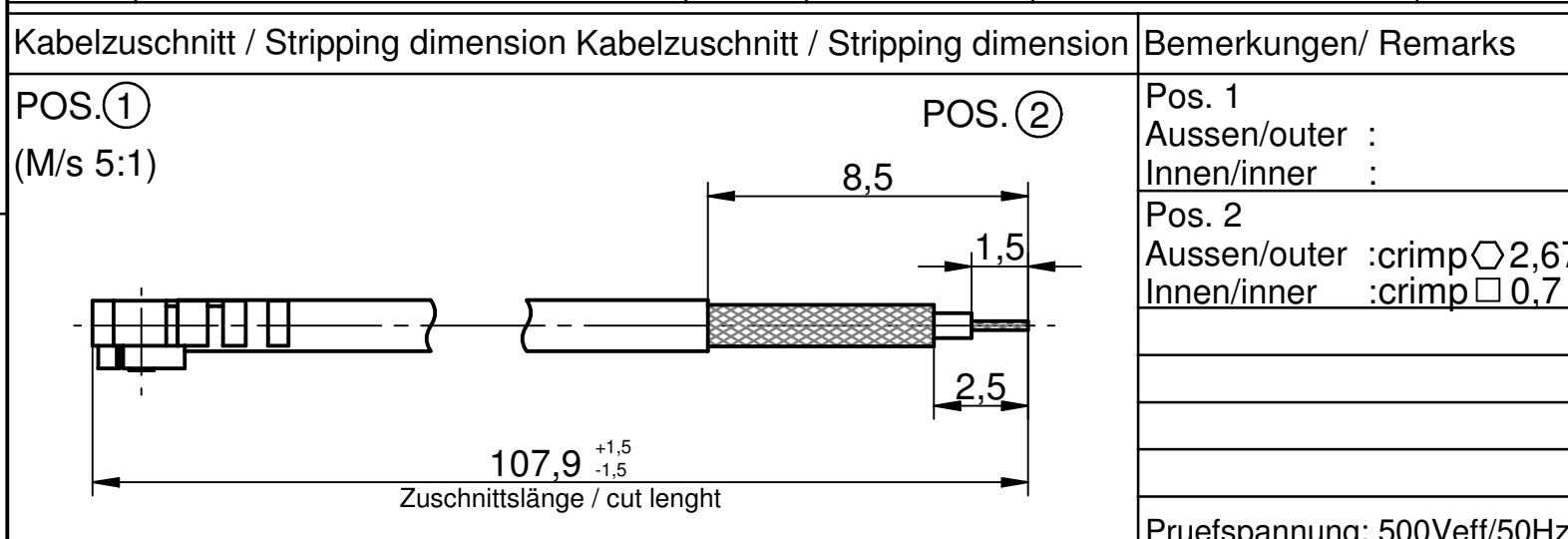

Befestigungsmutter, Dichtring und Fächerscheibe werden der Verpackung lose beigelegt. ^(a)
Coupling nut, sealing ring and fan disk are enclosed separately.

		general tolerance	scale: 1:1		
		AA-CS-12	Siemens AG		
	date	name	HF-Leitung Flexibel RF-flexible Cable Assembly		
generate	08.03.07	Pözl			
checked					
	Norm		K-2356		
EC 199 07 nr.	a rev.	Beilegeteil dazu alteration	19.10.07 date	Pözl name	Rev. a